

APPROVED	
SIGNATURE	DATE

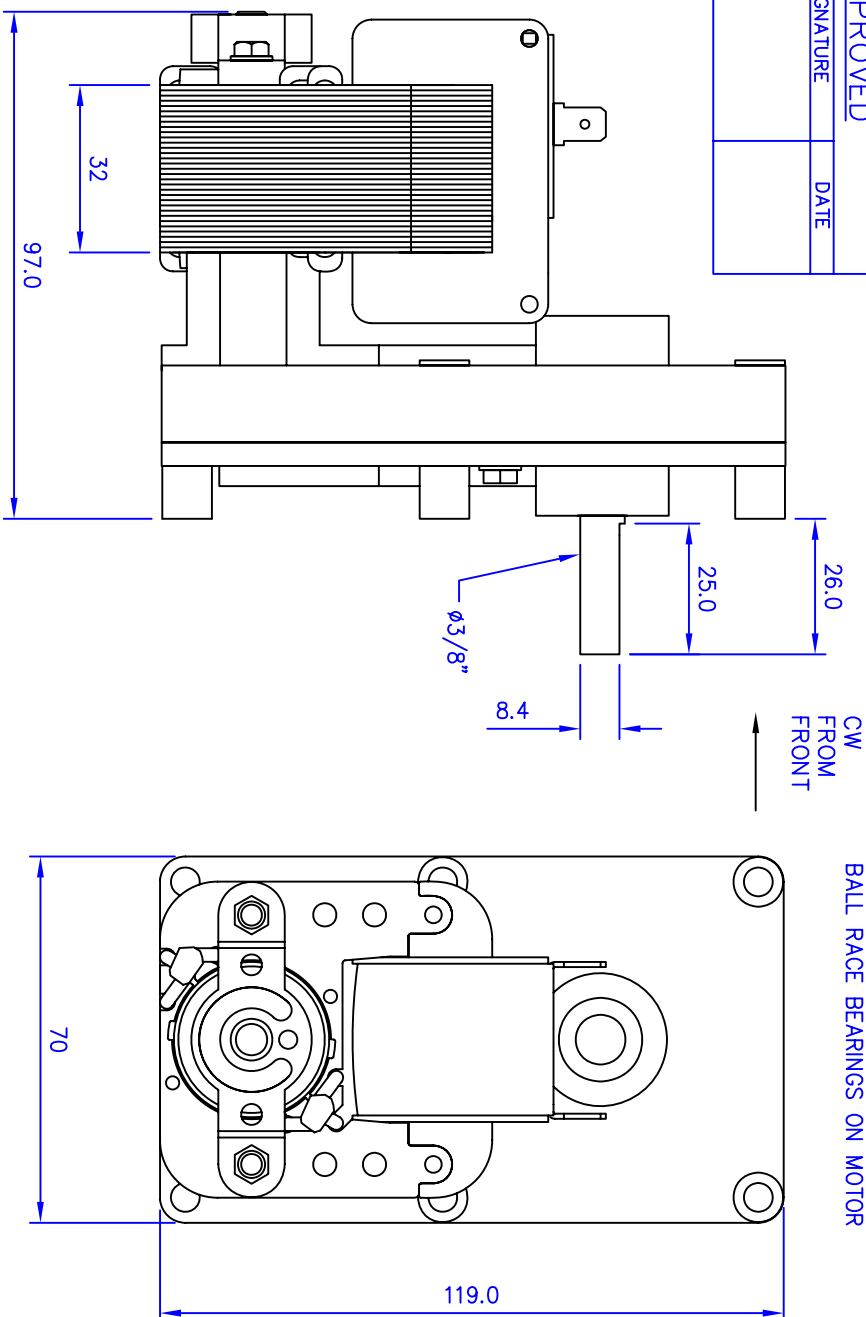

HELICAL INPUT
S.R.B.F. SHAFT 2 WHEEL
NOISE REDUCING GREASE
BALL RACE BEARINGS ON MOTOR

It is the customers responsibility to fully test for suitability in the application.

MOTOR SPEC

- MEM 390 (230v 50Hz)
- 1.25" BOBBIN (NYLON – GLASS FILLED CLASS F)
- SOLDERABLE POLYURETHANE WIRE (CLASS H, UL APPROVED)
- 125°C SELF RESETTING THERMOSTAT FITTED (UL APPROVED)
- 6.35mm MALE TAGS FITTED
- COVER WITH GLASS CLOTH TAPE (CLASS F)
- GEARBOX TO RUN CLOCKWISE WHEN VIEWED FROM THE FRONT

TECHNICAL DATA

INPUT POWER @ 230v 50Hz – 25WATTS
 NOMINAL CURRENT @ 230v 50Hz – 0.24Amps
 STALLED CURRENT @ 230v 50Hz – 0.37Amps
 STALL TORQUE @ 230v 50Hz – 25Nm (±10%)
 START TORQUE @ 230v 50Hz – 15Nm (±10%)
 NOISE LEVEL – 60dB max. 30cm from output shaft

MELLOR ELECTRICS Ltd	APPROVED	-	-	CUSTOMER	SOFTING ITALIA	PART No
BLACKBURN ENGLAND	DRAWN	LC	21/09/16	DESCRIPTION	SC9-125 3.3RPM 230v 50Hz	FB1263